

# NOTT Ref. EL05

5-section therapy table for a wide range of treatments in multiple positions. Equipped with a 3-section head which can be adjusted in both positive and negative angles. The armrests next to the head part can be raised and lowered when the patient is lying in prone position. 2 motors: 1 controlling the table height and the 2nd to adjust the middle section. Equipped as standard with paper roll holder.



TOP COLOUR

FRAME COLOUR



SKY BLUE  
A10



DARK GREY  
A66



	TOP	FRAME
EL05.2.A66.SH.WF	●	○
EL05.2.A66.SH.GF	●	●
EL05.2.A10.SH.WF	●	○

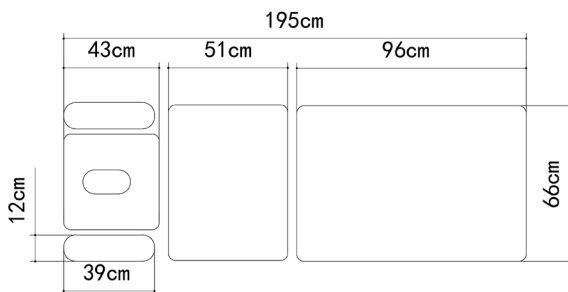
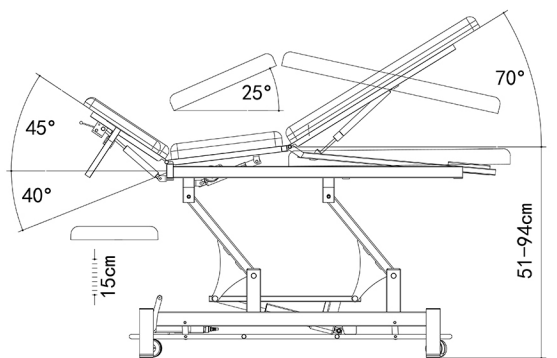

## Features:

- Electric Hi-Lo operation by perimeter foot bar
- Electric postural drainage operation by foot switch
- Sleek design with rounded frame legs for safety
- Height adjustable padded armrests
- Head section has face hole and plug
- Adjustable feet for uneven surfaces
- ø 75mm retractable castors for safety and mobility
- Reliable TiMOTION motor
- Height range from 51cm to 94cm in approx 30 seconds
- Padding thickness 5cm
- Foam Density: 36kg/m<sup>3</sup>
- Upholstery: Heavy duty PVC vinyl that is fire, stain, mildew, oil, water and wear resistant
- Certification: CE, FDA, ISO 13485:2016
- Weight Capacity: 250K
- Upholstery colours (choice: Sky blue or Dark grey)
- Warranty: 1 year for frame, electrical components and upholstery (except for misuse).



VIDEO



2 Motors



Certificate



250KG  
Max Loading



195 cm



66 cm



51-94 cm



Angle of headrest

-40° to +45°



Angle of chest

0° to +25°



Angle of leg plate

0° to +70°



76 kg



0.81 cm



195 x 70 x 58 cm

# NOTT Ref. EL05

Camilla de fisioterapia de 5 secciones para una amplia gama de tratamientos. Equipada con reposabrazos en cabecsal, ajustables en altura para asegurar la mejor posición cuando el paciente está tumbado en posición ventral. Dispone de 2 motores: ajuste de la altura de la camilla y cifosis eléctrica. Equipada de serie con portarrollos de papel.



TOP COLOUR

FRAME COLOUR



SKY BLUE  
A10



DARK GREY  
A66



	TOP	FRAME
EL05.2.A66.SH.WF	●	○
EL05.2.A66.SH.GF	●	●
EL05.2.A10.SH.WF	●	○

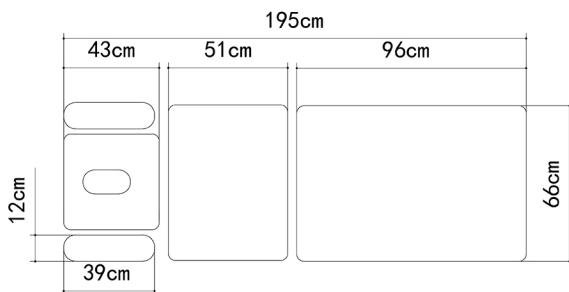
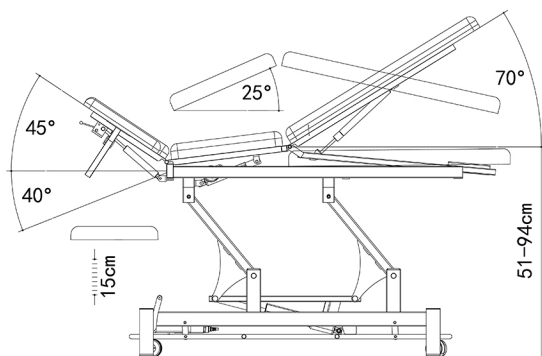

## Características:

- Ajuste eléctrico de la altura mediante control perimetral.
- Sección central ajustable (cifosis eléctrica).
- Diseño elegante con pies redondeados para mayor seguridad.
- Respaldo con agujero facial y tapón.
- Pies de nivelado para superficies irregulares.
- Ruedas escamoteables de  $\varnothing$  75mm.
- Motor de alta fiabilidad TIMOTION.
- Tiempo de elevación: 30 segundos.
- Grosor del acolchado: 5cm.
- Densidad de la espuma: 36kg/m<sup>3</sup>
- Tapizado de vinilo ignífugo muy resistente al desgaste.
- Certificaciones: CE, FDA, ISO 13485:2016
- Capacidad de carga: 250 kg
- Colores del tapizado (opciones: Azul o Gris oscuro)
- Garantía: 1 año para el chasis, componentes eléctricos y tapizado (salvo mal uso).



VIDEO



2 Motors



Certificate



Max Loading



195 cm



66 cm



51-94 cm



-40° to +45°



0° to +25°



0° to +70°



76 kg



0.81 m<sup>3</sup>



195 x 70 x 58 cm

# NOTT Ref. EL05

Table de thérapie à 5 sections pour une large gamme de traitements dans plusieurs positions. Équipée d'une tête à 3 sections réglable en proclive et déclive. Les accoudoirs situés à côté de la tête peuvent être relevés et abaissés lorsque le patient est allongé en position ventrale. 2 moteurs : 1 pour contrôler la hauteur de la table et le 2e pour la cyphose électrique. Équipée de série d'un porte-rouleau de papier.

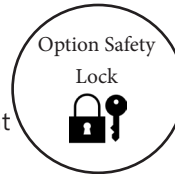

TOP COLOUR

FRAME COLOUR



SKY BLUE  
A10



DARK GREY  
A66



TOP FRAME

EL05.2.A66.SH.WF	●	○
EL05.2.A66.SH.GF	●	●
EL05.2.A10.SH.WF	●	○

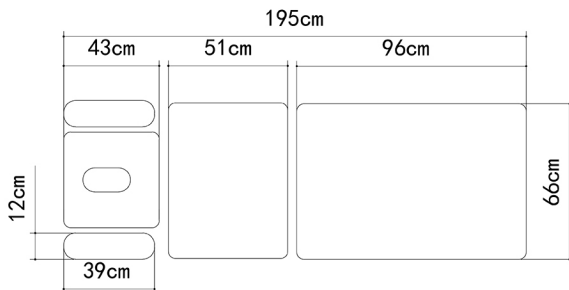
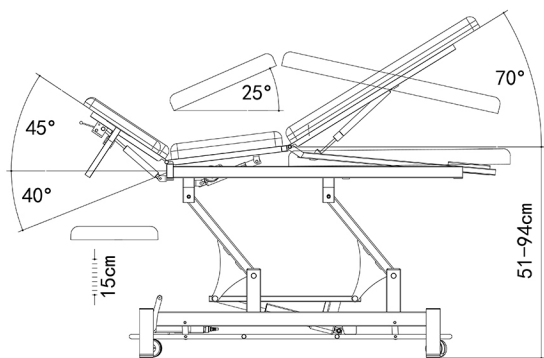

## Caractéristiques:

- Hauteur réglable par cadre de commande périphérique 360°.
- Cyphose électrique par commande à pied.
- Design élégant avec des pieds au cadre arrondis.
- Accoudoirs en tête, réglables en hauteur.
- Pieds réglables pour les surfaces inégales.
- Roulettes escamotables ø 75mm.
- Moteur fiable TiMOTION.
- Temps d'élévation: 30 secondes.
- Épaisseur de la mousse: 5 cm
- Densité de la mousse : 36 kg/m<sup>3</sup>
- Sellerie vinyle ignifugée très résistante à l'usure.
- Certification : CE, FDA, ISO 13485:2016
- Poids maximal supporté : 250 kg
- Couleur sellerie au choix : Bleu marine ou Gris graphite.
- Garantie : 1 an pour le châssis, vérins et sellerie (hors mauvaise utilisation).



VIDEO



2 Motors



Certificate



250KG  
Max Loading



195 cm



66 cm



51-94 cm



Angle of headrest

-40° to +45°



Angle of chest

0° to +25°



Angle of leg plate

0° to +70°



76 kg



0.81 m<sup>3</sup>



195 x 70 x 58 cm