

→
REF. 0010071
ELECTRIC WASHING UNIT



TECHNICAL FEATURES



Length:	129 cm
Length with extended footrest:	163 cm
Width:	66 cm
Height:	106 cm
Seat height:	49 cm
Weight:	82,8 kg
Voltage:	220-240 V
Frequency:	50/60 Hz
Motors:	1
Upholstery:	PVC ●
Sink:	Ceramic ● ○

MOTOR FUNCTIONS



- Folding chaise-longue footrest, with built-in control buttons.

SPECIFICATIONS



- Metallic interior structure.
- Deep and ergonomic tilting sink.
- INOX 304 drain valve with anti-hair basket and cap.
- Stainless steel sink support.
- High quality mixer tap (with INOX pipes) and chrome shower (with polyamide hose, silent to use).
- Removable backrest to make easier the installation and connections process.
- Seat and backrest with inside springs for better comfort.
- Extra padding in the lumbar area.

INCLUDES



- Basic neck protector.

ACCESSORIES



- Ton neck protector.

→
REF. 0010071
ELECTRIC WASHING UNIT



RECOMMENDED MINIMUM DISTANCES FOR THE INSTALLATION OF WASHING UNIT

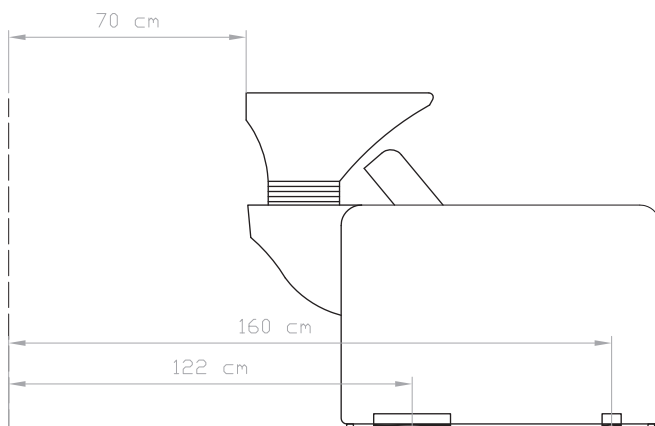
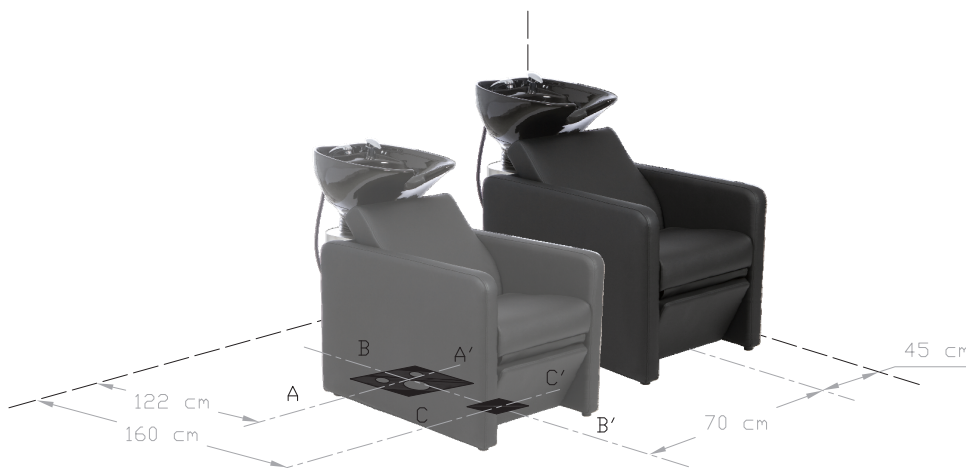

1. Drain Ø 40mm
2. Cold 3/8"
3. Hot 3/8"

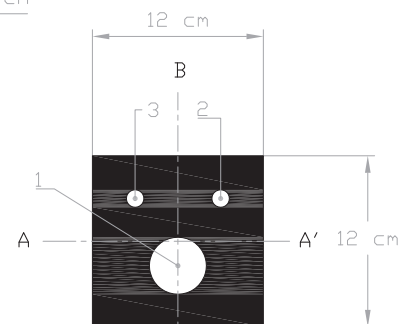

Electrical connection

